

This document shall be considered PVP Communications, Inc. proprietary information and not be disclosed to any third party without the prior written consent of PVP Communications, Inc.

TJ-105

Headset Jack

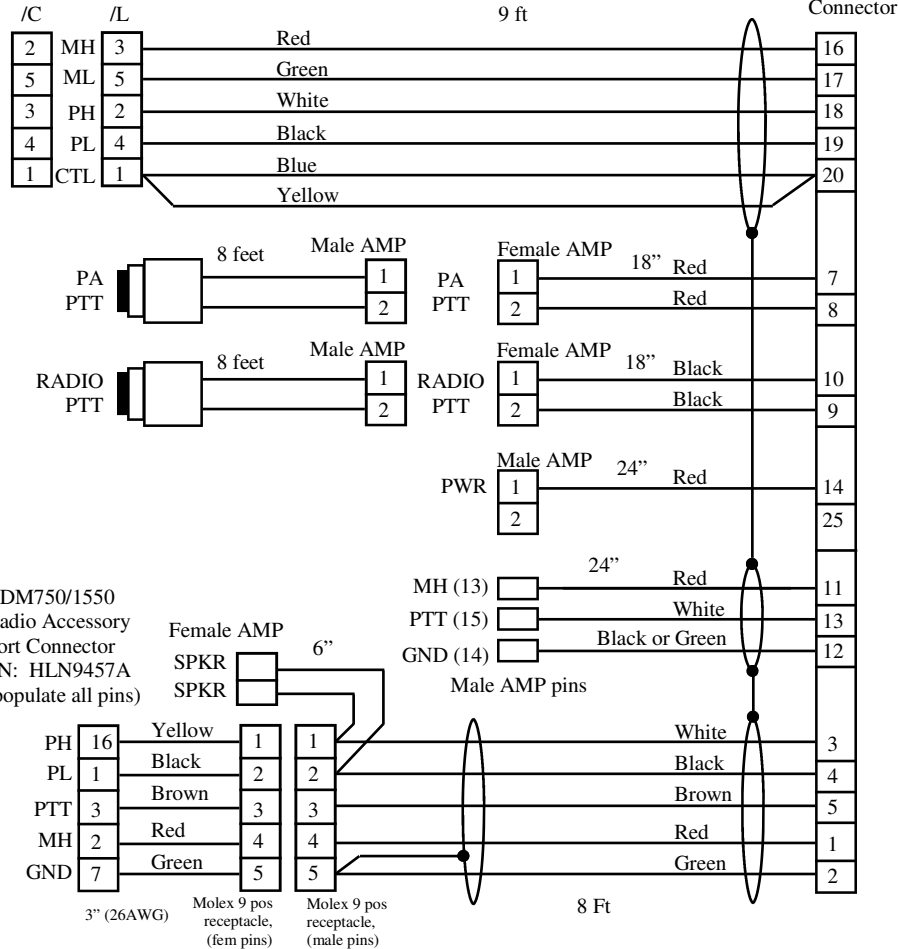

CDM750/1550  
Radio Accessory  
Port Connector  
PN: HLN9457A  
(populate all pins)

**NOTE:** When connecting to mobile radio, make sure to center on mating radio connector.

| Date       | Authorized | Description                            | Rev |
|------------|------------|--|-----|
| 07/22/2002 | MD         | Release                                | NC  |
| 01-15-04   | MD         | Add R & C to PA input signal           | A   |
| 01/18/04   | MD         | Add pigtail to radio for strain relief | B   |
| 6-28-08    | MD         | Remove R and C to PA for RT1200        | C   |

**NOTE:**

Kit includes: Harness Assy PVCDM75-A-C3-H01  
Module Assy PVPCB-BMW01 (not shown)

**NOTE:**

- Grind out holes in box and lid
- Cover shields in DB25 connector
- Center radio connector when installing on radio

**PART NUMBER:**

PVCDM75-  A-C3

| CODE | DESCRIPTION       |
|------|-------------------|
| B    | BMW PTT (no Brkt) |
| H    | Harley PTT        |
| K    | Kawasaki PTT      |
| G    | Generic PTT       |

| CODE | DESCRIPTION     |
|------|-----------------|
| /L   | Military Wiring |
| /C   | Nonstd Wiring   |

*PVP Communications, Inc*

|                  |  |
|------------------|--|
| Eng              | Title: Motor Kit, CDM750/1550 Mobile with Code3 Siren, Autoswitching Configuration |
| Check            |  |
| Date: 07/22/2002 |  |
| Sheet 1 of 1     | Drawing No: PVCDM75-A-C3   |