

This document shall be considered PVP Communications, Inc. proprietary information and not be disclosed to any third party without the prior written consent of PVP Communications, Inc.

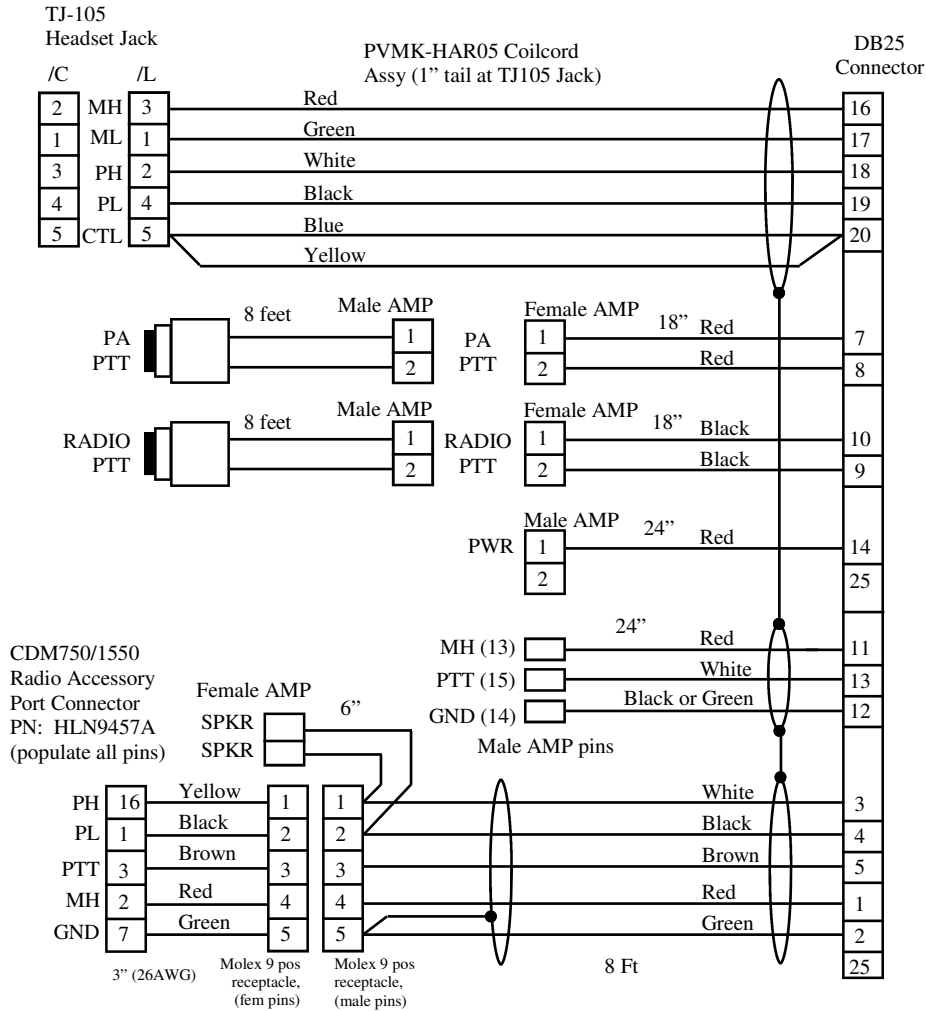

NOTE: When connecting to mobile radio, make sure to center on mating radio connector.

Date	Authorized	Description	Rev
07/22/2002	MD	Release	NC
01-15-04	MD	Add R & C to PA input signal	A
01/18/04	MD	Add pigtail to radio for strain relief	B
6-28-08	MD	Remove R and C to PA for RT1200	C

NOTE:
Kit includes: Harness Assy PVCDM75-AP-C3-H01
Module Assy PVPCB-BMW01 (not shown)

- NOTE:**
- Grind out holes in box and lid
 - Cover shields in DB25 connector
 - Center radio connector when installing on radio

PART NUMBER:

PVCDM75- AP-C3

CODE	DESCRIPTION
B	BMW PTT (no Brkt)
H	Harley PTT
K	Kawasaki PTT
G	Generic PTT

CODE	DESCRIPTION
/L	Military Wiring
/C	Nonstd Wiring

PVP Communications, Inc

Eng	Title: Motor Kit, CDM750/1550 Mobile with CODE3 Siren, Autoswitching, "P" Configuration
Check	
Date: 07/22/2002	
Sheet 1 of 1	Drawing No: PVCDM75-AP-C3