

This document shall be considered PVP Communications, Inc. proprietary information and not be disclosed to any third party without the prior written consent of PVP Communications, Inc.

TJ-105

Headset Jack

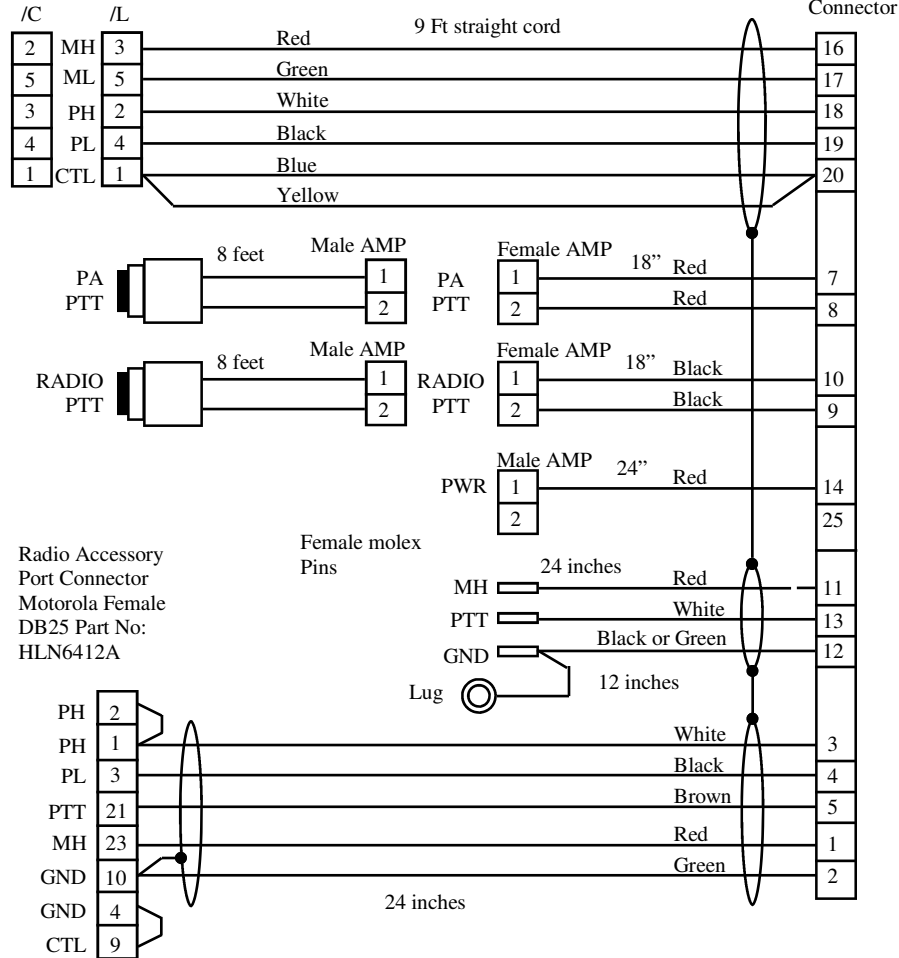

Date	Authorized	Description	Rev
10/11/2002	MD	Release	NC
02-06-03	MD	Delete cable to chassis	A
01-15-04	MD	Add R & C to PA input signal	B

**NOTE:**

Kit includes: Harness Assy PVMCS2-A-U8-H01  
Module Assy PVPCB-BMW01 (not shown)

**NOTE:**

- Cover shields in DB25 connector

**PART NUMBER:**

PVMCS2-  A-U8

CODE	DESCRIPTION
B	BMW PTT (no Brkt)
H	Harley PTT
K	Kawasaki PTT
G	Generic PTT

CODE	DESCRIPTION
/L	Military Wiring
/C	Nonstd Wiring

*PVP Communications, Inc*

Eng	Title: Motor Kit, Motorola MCS2000 Mobile with Unitrol 80K Siren, Autoswitching Configuration
Check	
Date: 10/14/2002	
Sheet 1 of 1	Drawing No: PVMCS2-A-U8