

This document shall be considered PVP Communications, Inc. proprietary information and not be disclosed to any third party without the prior written consent of PVP Communications, Inc.

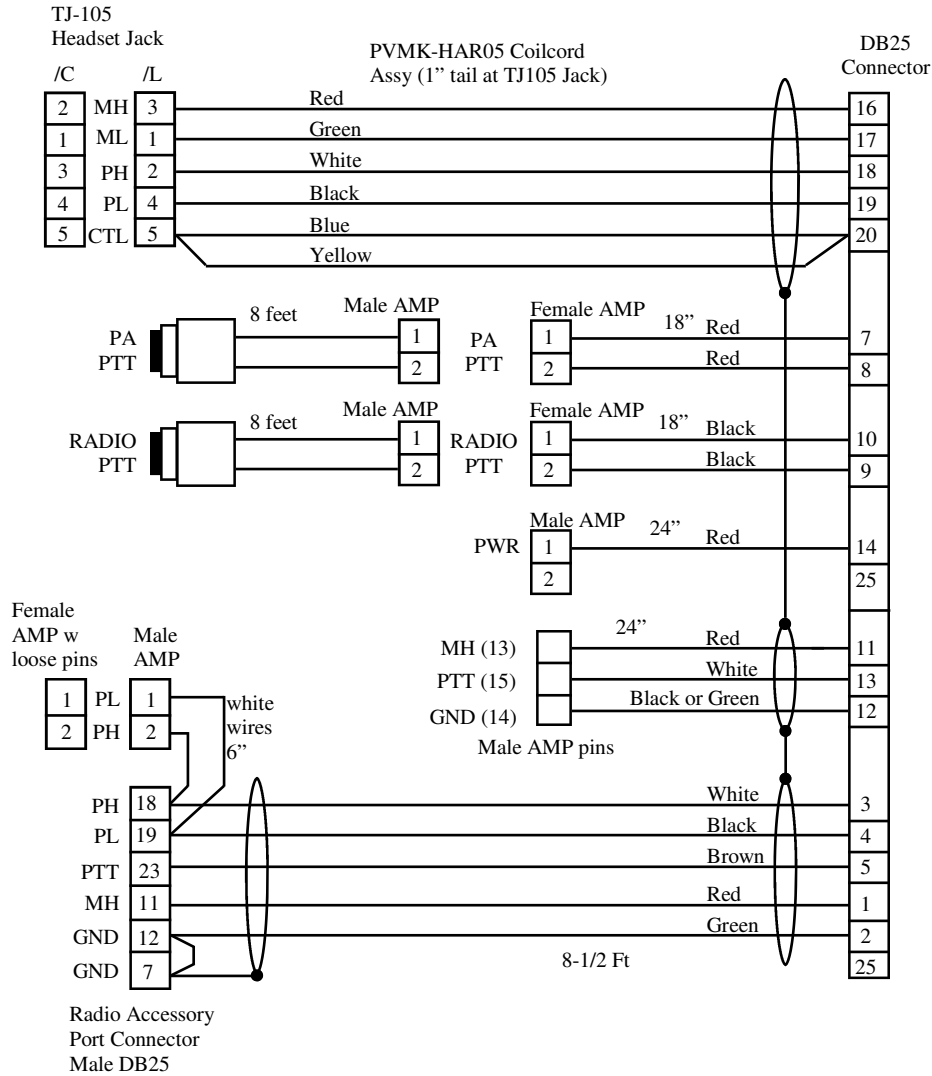

Date	Authorized	Description	Rev
10/11/2002	MD	Release	NC
01-15-04	MD	Add R & C to PA input signal	A
6-28-08	MD	Remove R and C from PA for Rt1200	B

**NOTE:**  
Kit includes: Harness Assy PVORI-AP-C3-H01  
Module Assy PVPCB-BMW01 (not shown)

- NOTE:**
- Grind out holes in box and lid
  - Cover shields in DB25 connector

**PART NUMBER:**  
PVORI-  AP-C3

CODE	DESCRIPTION
B	BMW PTT (no Brkt)
H	Harley PTT
K	Kawasaki PTT
G	Generic PTT

CODE	DESCRIPTION
/L	Military Wiring
/C	Nonstd Wiring

*PVP Communications, Inc*

Eng	Title: Motor Kit, ORION Mobile with Code3 Siren, Autoswitching, "P" Configuration
Check	
Date: 10/14/2002	
Sheet 1 of 1	Drawing No: PVORI-AP-C3