

This document shall be considered PVP Communications, Inc. proprietary information and not be disclosed to any third party without the prior written consent of PVP Communications, Inc.

TJ-105

Headset Jack

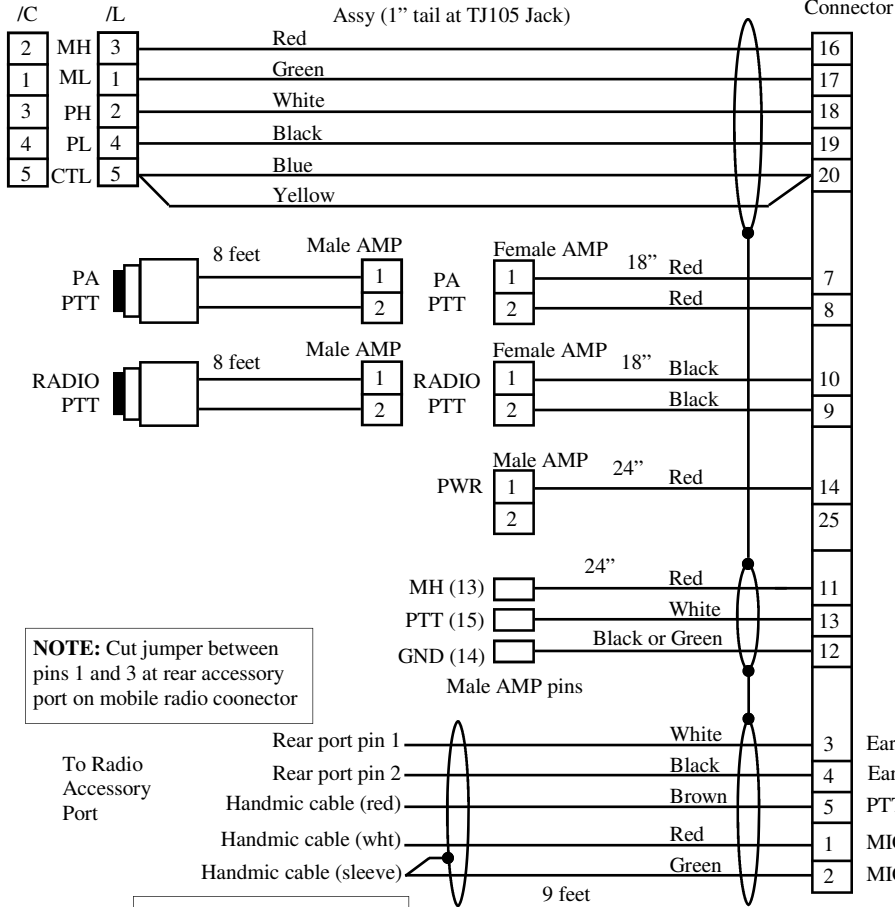

**NOTE:** Cut jumper between pins 1 and 3 at rear accessory port on mobile radio connector

**NOTE:** Remove handmic, disconnect wiring in housing and connect to motor kit as follows:

Date	Authorized	Description	Rev
07/22/2002	MD	Release	NC
02-06-03	MD	Delete cable to chassis	A
01-15-04	MD	Add R & C to PA input signal	B
6-28-08	MD	Remove R and C from PA for RT1200	C

**NOTE:**  
Kit includes: Harness Assy PVSMT-AP-C3-H01  
Module Assy PVPCB-BMW01 (not shown)

- NOTE:**
- Grind out holes in box and lid
  - Cover shields in DB25 connector

**PART NUMBER:**

PVSMT-  AP-C3

CODE	DESCRIPTION
B	BMW PTT (no Brkt)
H	Harley PTT
K	Kawasaki PTT
G	Generic PTT

CODE	DESCRIPTION
/L	Military Wiring
/C	Nonstd Wiring

*PVP Communications, Inc*

Eng	Title: Motor Kit, BMW, SUMMIT Mobile with CODE3 Siren, Autoswitching, "P" Configuration
Check	
Date: 07/22/2002	
Sheet 1 of 1	Drawing No: PVSMT-AP-C3