

This document shall be considered PVP Communications, Inc. proprietary information and not be disclosed to any third party without the prior written consent of PVP Communications, Inc.

TJ-105

Headset Jack

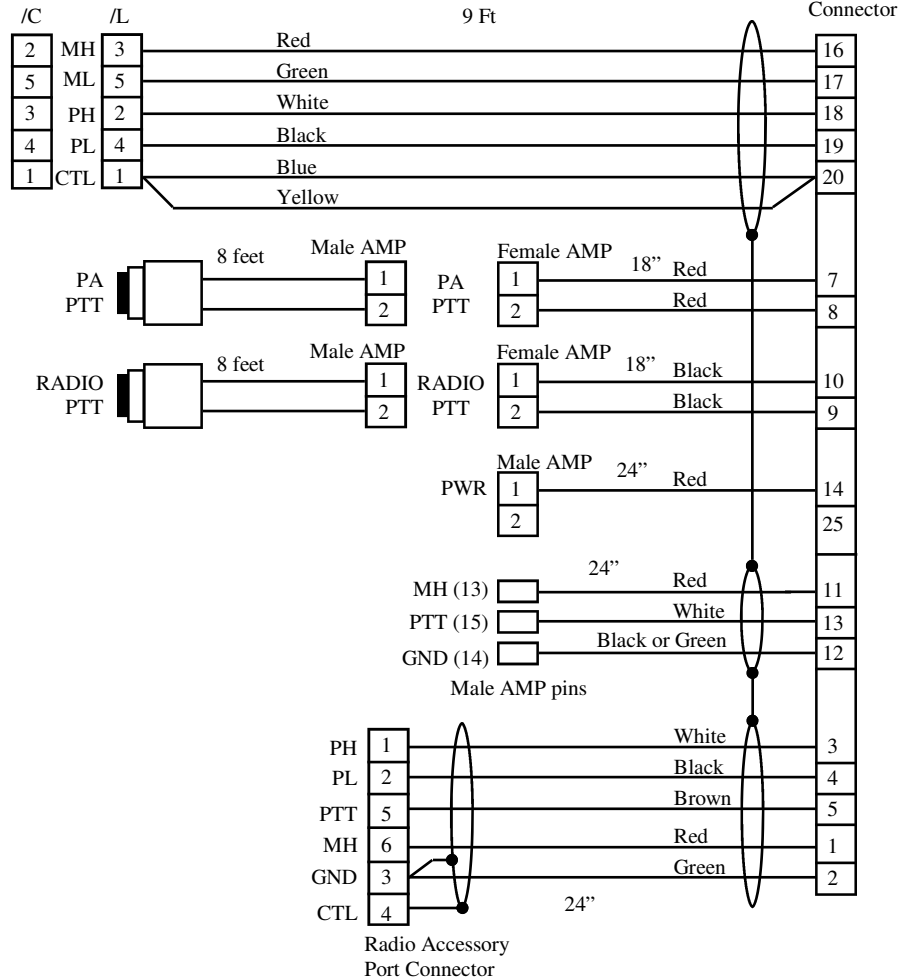

Date	Authorized	Description	Rev
07/22/2002	MD	Release	NC
02-06-03	MD	Delete Chassis Lead	A
03-16-04	MD	Add R & C to PA input signal	B
6-28-08	MD	delete R & C to PA for RT1200	C

NOTE:

Kit includes: Harness Assy PVSP-A-C3-H01
Module Assy PVPCB-BMW01 (not shown)

NOTE:

- Grind out holes in box and lid
- Cover shields in DB25 connector

PART NUMBER:

PVSP- A-C3

CODE	DESCRIPTION
B	BMW PTT (no Brkt)
H	Harley PTT
K	Kawasaki PTT
G	Generic PTT

CODE	DESCRIPTION
/L	Military Wiring
/C	Nonstd Wiring

PVP Communications, Inc

Eng	Title: Motor Kit, SPECTRA Mobile with CODE3 Siren, Autoswitching, Configuration
Check	
Date: 03/16/2004	
Sheet 1 of 1	Drawing No: PVSP-A-C3