

This document shall be considered PVP Communications, Inc. proprietary information and not be disclosed to any third party without the prior written consent of PVP Communications, Inc.

TJ-105

Headset Jack

PVMK-HAR05 Coilcord
Assy (1" tail at TJ105 Jack)

DB25
Connector

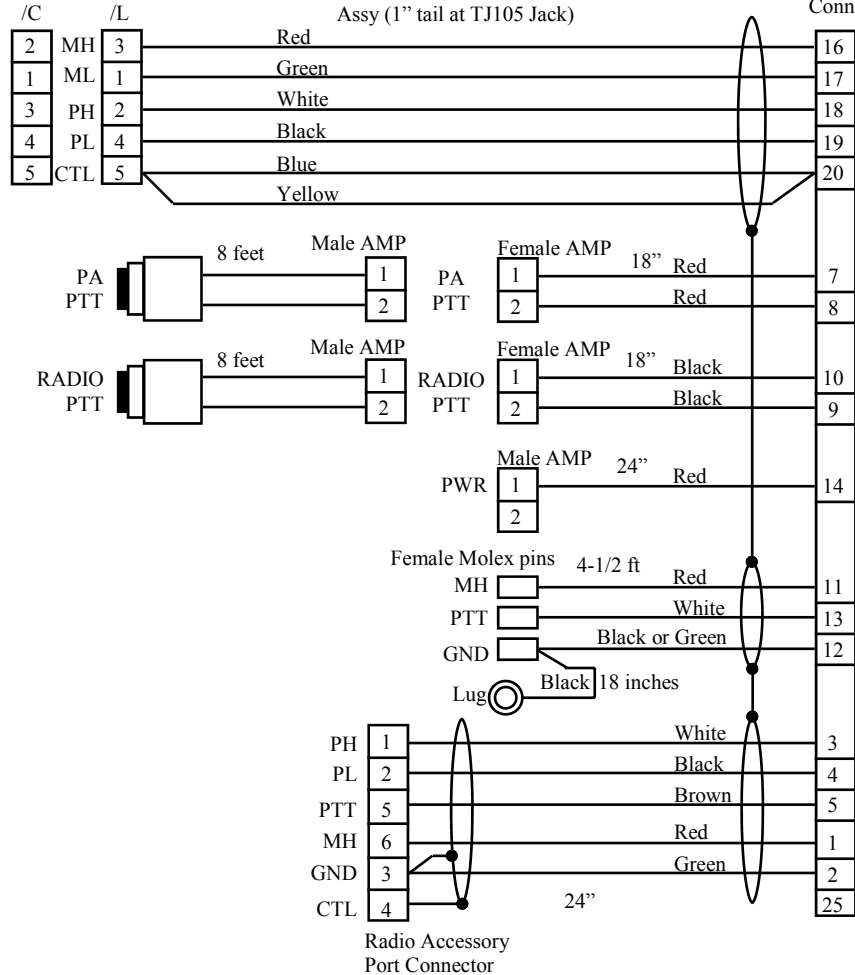

Date	Authorized	Description	Rev
07/22/2002	MD	Release	NC
02/6/2003	MD	Delete cable to chassis, add GND	A

NOTE:
Kit includes: Harness Assy PVSP-AP-U8-H01
Module Assy PVPCB-BMW01 (not shown)

- NOTE:**
- Grind out holes in box and lid
 - Cover shields in DB25 connector

PART NUMBER:

PVSP- AP-U8

CODE	DESCRIPTION
B	BMW PTT (no Brkt)
H	Harley PTT
K	Kawasaki PTT
G	Generic PTT

CODE	DESCRIPTION
/L	Military Wiring
/C	Nonstd Wiring

PVP Communications, Inc

Eng	Title: Motor Kit, SPECTRA Mobile w/ Unitrol 80K Siren, Autoswitching, "P" Configuration
Check	
Date: 07/22/2002	
Sheet 1 of 1	Drawing No: PVSP-AP-U8