

This document shall be considered PVP Communications, Inc. proprietary information and not be disclosed to any third party without the prior written consent of PVP Communications, Inc.

TJ-101

Headset Jack

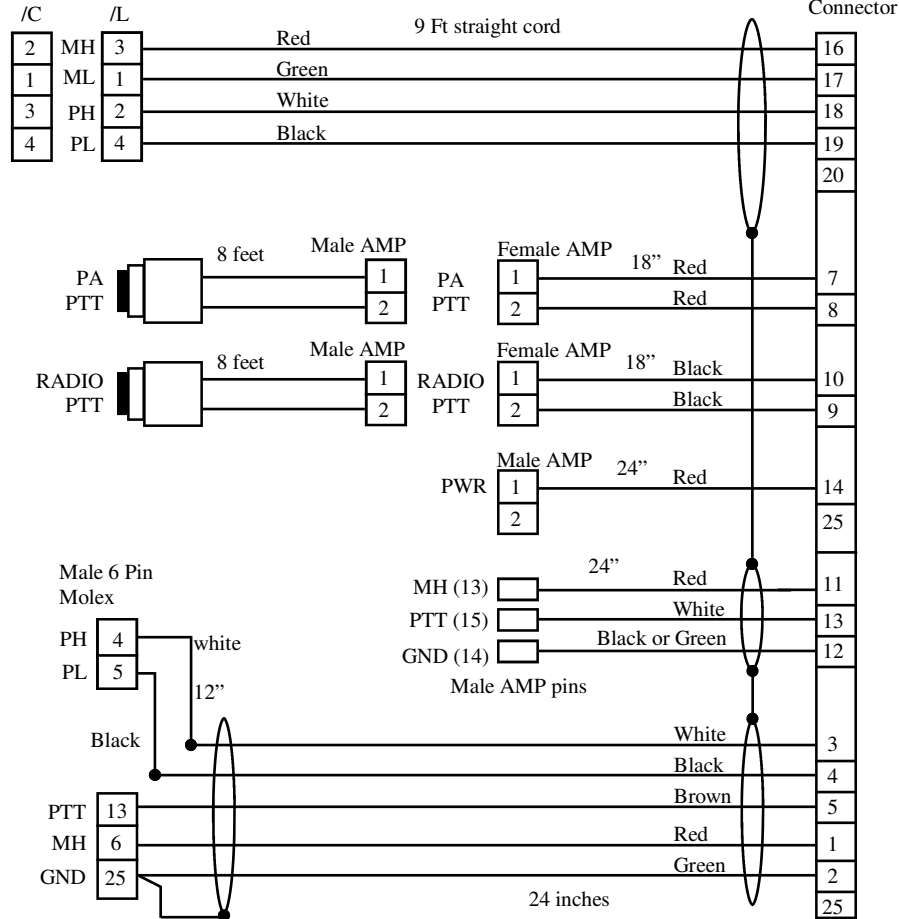

Radio Accessory  
Port Connector  
Male DB25

Date	Authorized	Description	Rev
10/11/2002	MD	Release	NC
6-28-08	MD	Remove R and C from PA for RT1200	A

**NOTE:**

Kit includes: Harness Assy PVTK7150-P-C3-H01  
Module Assy PVPCB-BMW01 (not shown)

**NOTE:**

- Grind out holes in box and lid
- Cover shields in DB25 connector

**PART NUMBER:**

PVTK7150-  P-C3

CODE	DESCRIPTION
B	BMW PTT (no Brkt)
H	Harley PTT
K	Kawasaki PTT
G	Generic PTT

CODE	DESCRIPTION
/L	Military Wiring
/C	Nonstd Wiring

*PVP Communications, Inc*

Eng	Title: Motor Kit, TK7150 Mobile with Code3 Siren Configuration
Check	
Date: 10/14/2002	
Sheet 1 of 1	Drawing No: PVTK7150-P-C3