

This document shall be considered PVP Communications, Inc. proprietary information and not be disclosed to any third party without the prior written consent of PVP Communications, Inc.

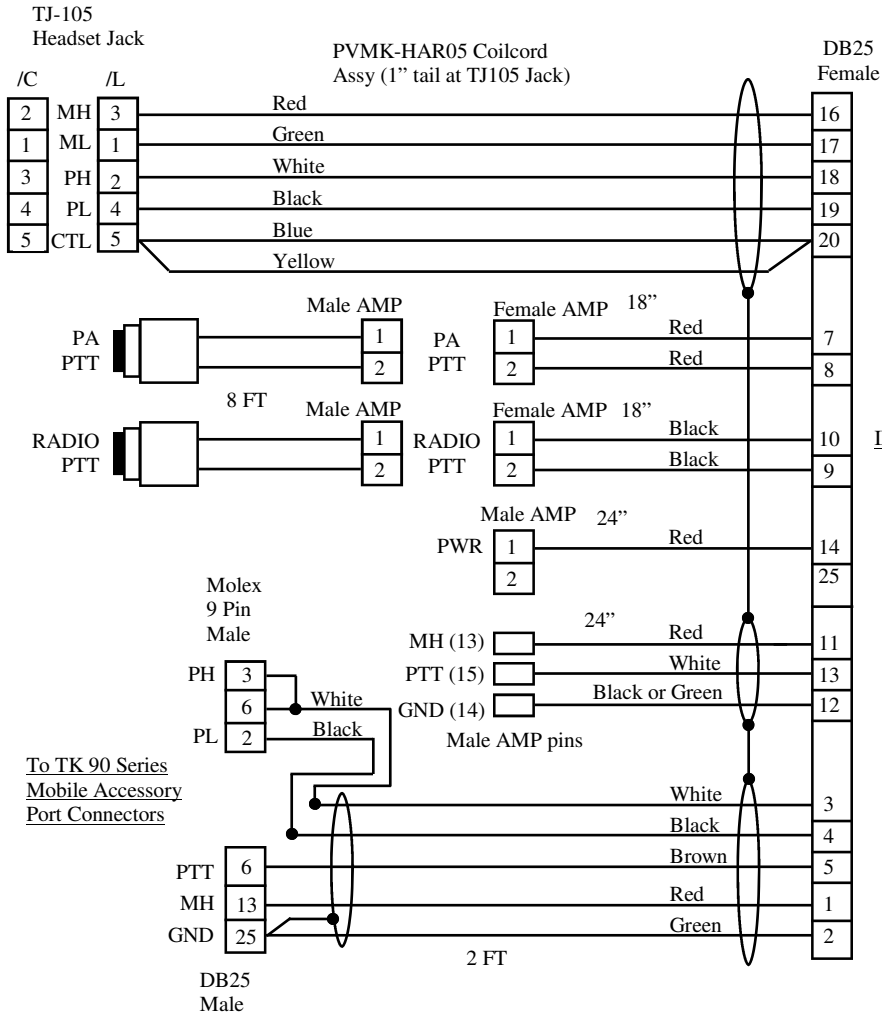

Date	Authorized	Description	Rev
02/27/2002	MD	Release	NC
02-06-03	MD	Delete cable to chassis	A
01-15-04	MD	Add R & C to PA input signal	B
6-28-08	MD	Remove R and C from PA for Rt1200	C

NOTE:
Kit includes: Harness Assy PVTK79-AP-C3-H01
Module Assy PVPCB-BMW01 (not shown)

- NOTE:**
- Grind out holes in box and lid
 - Cover shields in DB25 connector

TO
INTERFACE
CONTROL
MODULE

PART NUMBER:

PVTK79- AP-C3

CODE	DESCRIPTION
B	BMW PTT (no Brkt)
H	Harley PTT
K	Kawasaki PTT
G	Generic PTT

CODE	DESCRIPTION
/L	Military Wiring
/C	Nonstd Wiring

PVP Communications, Inc

Eng	Title: Motor Kit, TK90 Series Mobile Radio, Autoswitching, with CODE3 Siren
Check	
Date: 02/27/2002	Drawing No: PVTK79-AP-C3
Sheet 1 of 1	