

This document shall be considered PVP Communications, Inc. proprietary information and not be disclosed to any third party without the prior written consent of PVP Communications, Inc.

TJ-105

Headset Jack

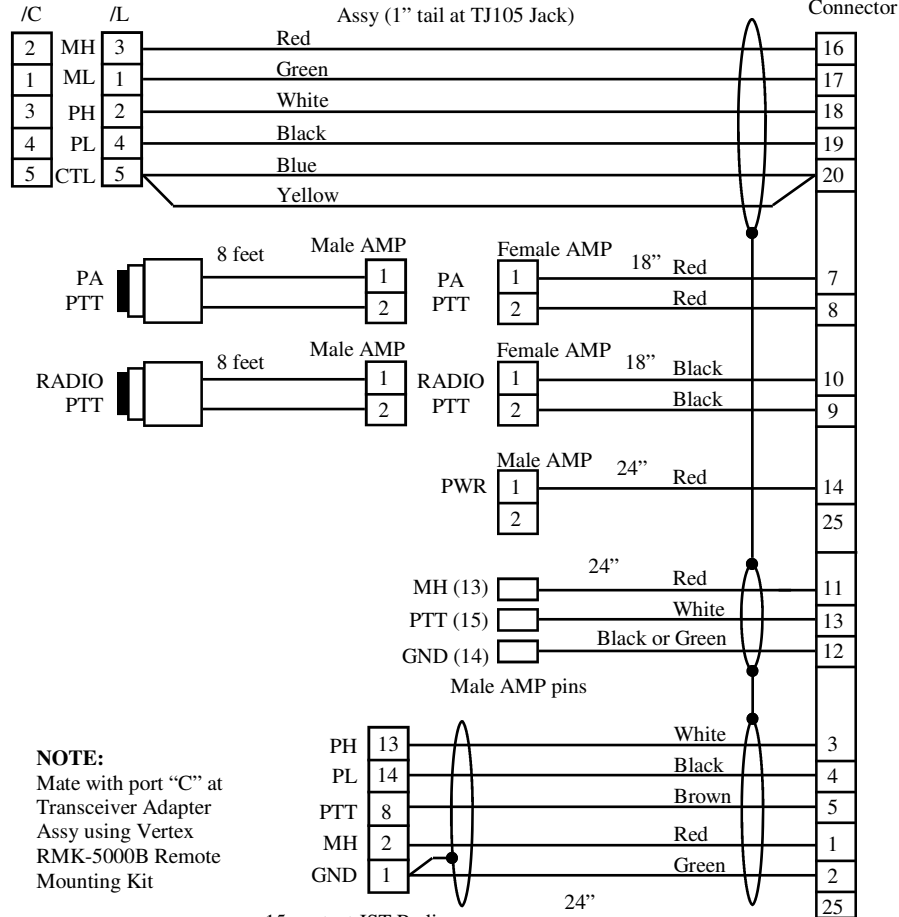

**NOTE:**  
Mate with port "C" at Transceiver Adapter Assy using Vertex RMK-5000B Remote Mounting Kit

15 contact JST Radio Accessory Connector  
SPH-002T-P0.5S (pins)  
PHR-15 (housing)

Date	Authorized	Description	Rev
09/22/2004	MD	Release	NC
6-28-08	MD	Remove R and C from PA for RT1200	A

**NOTE:**

Kit includes: Harness Assy PVVX-AP-C3-H01  
Module Assy PVPCB-BMW01 (not shown)

**NOTE:**

- Grind out holes in box and lid
- Cover shields in DB25 connector

**PART NUMBER:**

PVVX--AP-C3-

CODE	DESCRIPTION
B	BMW PTT (no Brkt)
H	Harley PTT
K	Kawasaki PTT
G	Generic PTT

CODE	DESCRIPTION
/L	Military Wiring
/C	Nonstd Wiring

*PVP Communications, Inc*

Eng	Title: Motor Kit, Vertex VX Series Mobile with CODE3 Siren, Autoswitching, "P" Configuration
Check	
Date: 09/22/2004	
Sheet 1 of 1	Drawing No: PVVX-AP-C3