

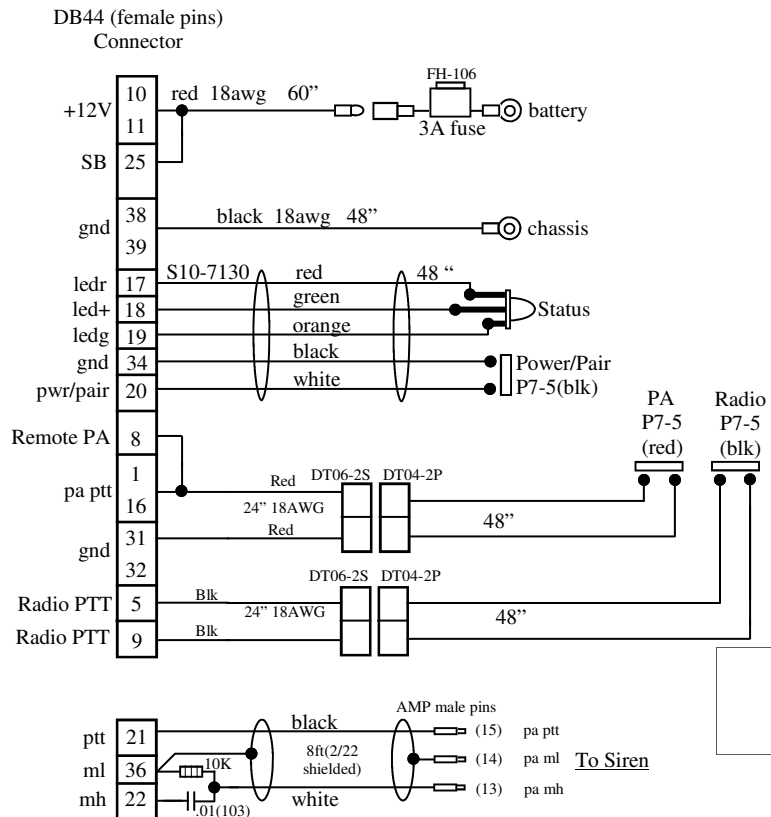

This document shall be considered PVP Communications, Inc. proprietary information and not be disclosed to any third party without the prior written consent of PVP Communications, Inc.			
Date	Authorized	Description	Rev
04/28/2006	MD	Release	NC
06-25-07	MD	Change to use with PVG2AS Module	A
05-27-09	MD	Add cap and resistor to PA	B

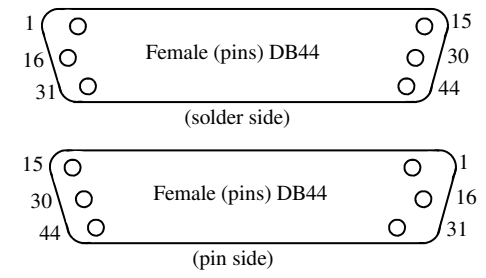

**LABEL:**  
 PV-RT12-C3-XMH  
 Rev B



- NOTES:**
- 1) Assemble L30022 lens cap to LED, cover with adhesive sleeve, and install into GRM219P grommet
  - 2) Label as shown and include installation instructions
  - 3) Ream DB44 (plastic) backshell with 1/2" Drill
  - 4) Complete assembly includes Module (PN: PVG2AS) (not shown), PTT Assembly PN: PVPTT-B02-DT, and Harness Assembly PN: PV-RT12-C3-XMH
  - 5) Use P7-5 switch with 10179B boot, and N5040R-red or N5040R-blk cover. Include star washer for each switch.
  - 6) Drill 1/4" hole to install P7-5 switches on motor, drill 11/32" hole to install LED grommet on motor
  - 7) Include dual RT1200 PTT bracket (not shown) PN: PVRT12PTT-02

**PVP** Communications 

Eng	Title: Motor Kit, Portable-Only with CODE3 Siren, G2 Wireless, for BMW RT1200
Check	
Date: 06/25/2007	
Sheet 1 of 1	Drawing No: PV-RT12-C3/XM



# INSTALLATION DIAGRAM

Included in this Kit:

- 1) Control Module: PVG2AS
- 2) Harness Assembly: PV-RT12-C3-XMH
- 3) PTT Bracket: PVRT12PTT-02
- 4) PTT Assembly: PVPTT-B02-DT
- 5) Tie Wraps (15)

**QUESTIONS? call us at 800-584-4119 Monday through Friday, 7AM to 4PM Pacific Time, USA.**

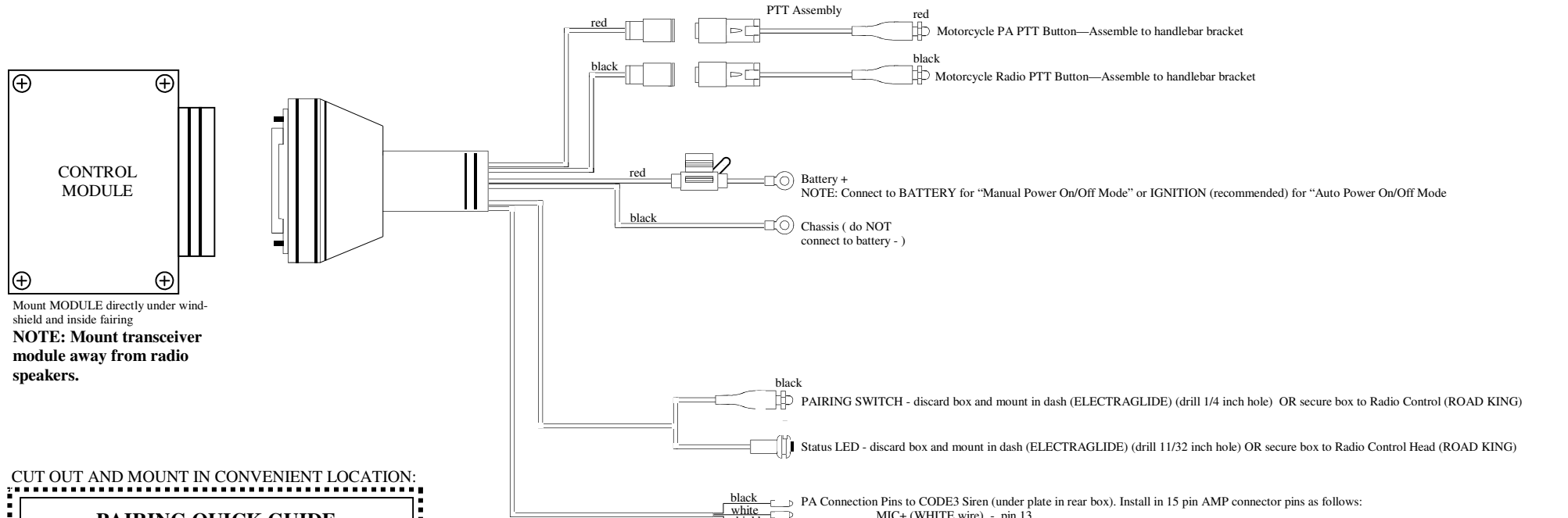

Mount MODULE directly under windshield and inside fairing

**NOTE: Mount transceiver module away from radio speakers.**

**CUT OUT AND MOUNT IN CONVENIENT LOCATION:**

### PAIRING QUICK GUIDE

**NOTE: All other Bluetooth devices in the immediate area must be powered off.**

- 1) Power off both devices. Press each PAIR switch until LED goes to a solid color (2-3 seconds), then release.
- 2) Press and hold *Motor* PAIR switch until LED toggles red-green-red-green, then release it and immediately:
- 3) Press and hold *Shouldermic* PAIR switch until LED toggles red-green-red-green, then release.
- 4) After 10-15 seconds, a green pulse will confirm PAIR is established.

**PA VOLUME:**

Adjust the helmet microphone PA transmit volume with a small flat screwdriver on the siren amplifier (located on the right side of the siren amplifier).

NOTE: An additional gain adjust is available in the Control Module if additional volume adjustment is needed.

NOTE: When testing PA volume, make sure the siren speaker is directed to an open area to avoid improper feedback.

NOTE: When testing PA volume, make sure the helmet microphone is on axis (not rotated) and held close to the users mouth (within 1/4").

# **PROGRAMMING**

**SYSTEM PAIRING:** The motor kit must be “paired” to a shouldermic. This creates a unique wireless link between the shouldermic and the motor kit. Once a pairing procedure has been performed, the link is “remembered” by both. A new pair may be established at any time, but until then, the shouldermic and the motor kit will remain “faithful”, responding only to their mate. They will remember who their mate is—even after having been powered off.

A) Connect helmet to shouldermic. The shouldermic will power on and the LED will begin to flash.

**NOTE:** Helmet must be connected to the shouldermic to power on.

B) Power off by pressing the pairing switch for 2-3 seconds until the LED transitions to a solid color, then release.

C) Activate the Motor Kit - the motor status LED will begin to flash. Manually power off the Motor Kit by pressing the pairing switch for 2-3 seconds until the status LED transitions to a solid color. Then release.

D) From the powered off condition, press the Motor Kit pairing switch for 7-9 seconds until the LED begins toggling red-green-red-green, then release. The motor has powered on into pairing mode and is searching for a mate.

E) *Immediately after releasing the switch at the motor*, press the pairing switch at the shouldermic (from the powered off condition) for 7-9 seconds until the LED begins toggling red-green-red-green, then release. The shouldermic has now powered on into pairing mode and searching for a mate.

Within 15 seconds both devices will display a green status LED pulse, indicating that they have been successfully paired to each other.

## **POWER ON/OFF MODES:**

**NOTE:** Motor Kits are factory set for auto power-on mode where they will power on automatically whenever 12VDC is applied to the fused battery wire. It is recommended to connect the fused battery wire to motorcycle ignition power and leave the Kit in the auto power-on mode.

The Motor Kit may be configured for “auto power-on” mode or “manual power-on” mode:

“Auto power-on” mode causes the motor kit to power on automatically whenever it is provided with battery power through the fused battery wire.

“Manual power-on” mode allows the motor kit to be powered on/off manually with the “Pairing” switch. To perform a manual power-on, make sure 12VDC is applied to the fused battery wire (it’s recommended to keep the fused battery wire directly connected to the battery for use of this mode), then press and hold the Power switch for 2-3 seconds until the Status LED lights. Release the switch.

**NOTE:** Reverse the 2-3 second procedure to manually power off.

### Changing power-on modes

Verify the Kit is powered on (LED flashing). Press the pairing switch quickly 5 times within one second to place the kit in manual power-on mode. Press the pairing switch quickly 4 times within one second to place the kit in auto power-on mode.



# **INSTALLATION and OPERATING INSTRUCTIONS**

## **Motor-One™ Wireless Portable Radio Interface Kit with PA Broadcast for Police Motorcycles**

**United States Patents: 7,062,301 6,311,052 7,203,525**

*QUESTIONS? call us at 800-584-4119 Monday through Friday, 7AM to 4PM Pacific Time, USA.*

## **OPERATION**

### **HELMET DISCONNECTED**

- 1) Attach shouldermic to portable radio, turn the radio on.
- 2) Press shouldermic PTT switch to transmit.

**NOTE:** An additional PTT switch is located on the radio connector.

- 3) Receive audio will play at the shouldermic speaker.

### **HELMET ATTACHED**

- 1) Attach headset to shouldermic.
- 2) The following will occur:
  - A) The shouldermic speaker will mute and portable radio will play at the helmet earphones.
  - B) The helmet microphone will now be activated when PTT switch is pressed.
  - C) The wireless transceiver will power-on (auto power-on mode) and the status LED will begin flashing.

**NOTE:** The shouldermic contains a rechargeable battery that powers the internal wireless transceiver, and should be charged each day. Charger connects at the headset connector port.

### **MOTORCYCLE HANDLEBAR SWITCHES**

When paired (see **PAIRING** procedure) and powered on (see **POWER ON/OFF MODES**), the shouldermic and motor kit status LED’s will display a green pulse, allowing the following:

- 1) The black handlebar PTT switch will activate portable radio transmit using the helmet microphone.
- 2) The red handlebar PTT switch will activate PA broadcast using the helmet microphone.

**NOTE:** Any PTT switch can be used *at any time*.